

# RM43-320-RS

4U 20-bay 2.5"/3.5" HDD rackmount storage chassis with Mini-SAS HD SFF-8643 12 Gb/s interface

SilverStone Technology Co., Ltd.

[www.silverstonetek.com](http://www.silverstonetek.com)

[support@silverstonetek.com](mailto:support@silverstonetek.com)

NO: G11244060

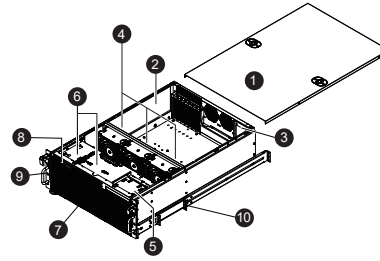

- 1 TOP COVER
- 2 BOTTOM CHASSIS
- 3 OPTIONAL POWER SUPPLY
- 4 Hot-swap 120x38mm FANS
- 5 ODD DRIVE CAGE
- 6 2.5" DRIVE CAGE
- 7 2.5"/3.5" HDD TRAY
- 8 FRONT PANEL IO AND INDICATORS
- 9 RACK HANDLES
- 10 RAIL SLIDE

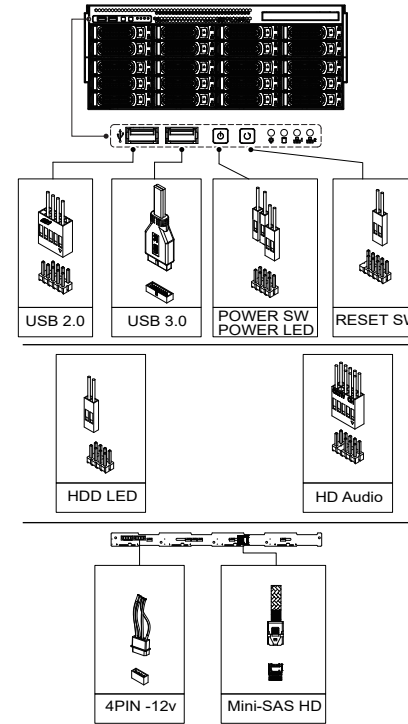

1. Press and hold the top cover's two buttons while pushing the cover towards the rear of the chassis to remove it

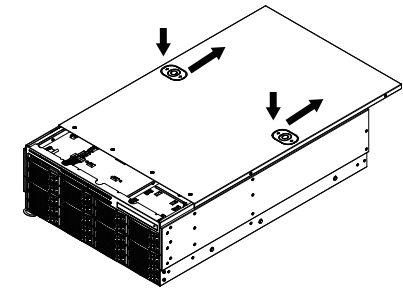

2. Install the motherboard stand-off, then install motherboard and secure with screws

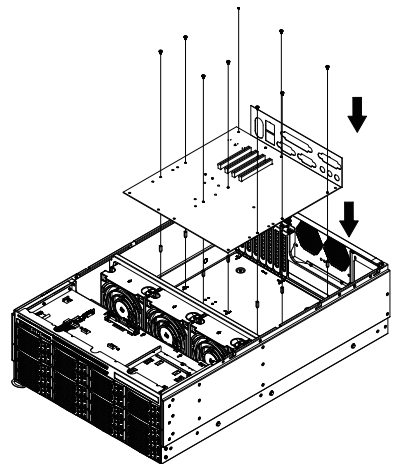

3. Install PSU into chassis then secure with screws

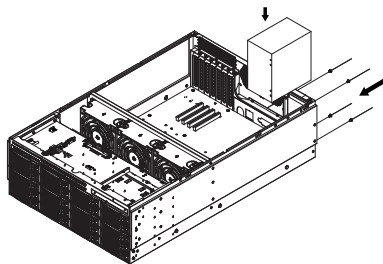

4. Install 2.5" drive onto plastic clip

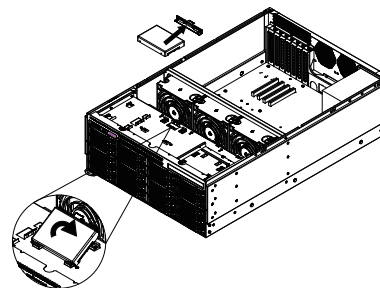

5. Remove the optical drive bracket, secure optical drive onto the bracket then install back into the chassis

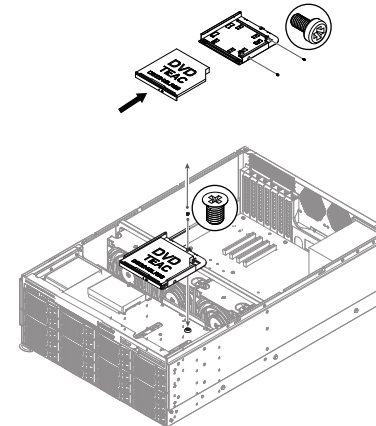

6-1 Install graphics / expansion cards  
Remove PCI slot covers

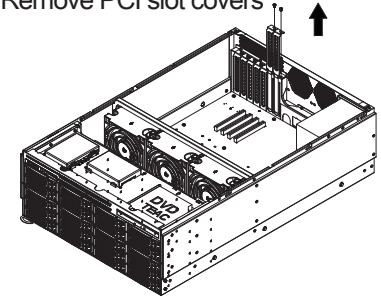

6-2 Install graphics / expansion cards

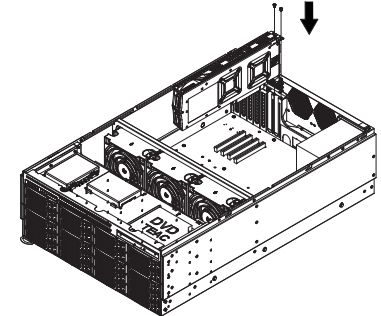

7. Remove the hot-swappable fans, connect all the relevant connectors, then secure back into the chassis

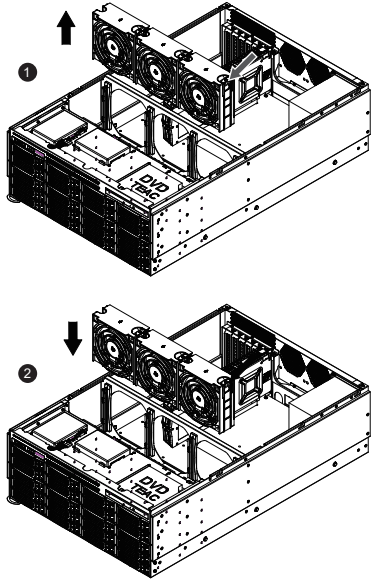

8. Remove the front hard drive tray, secure 2.5" or 3.5" drives on to the tray, then secure back into chassis

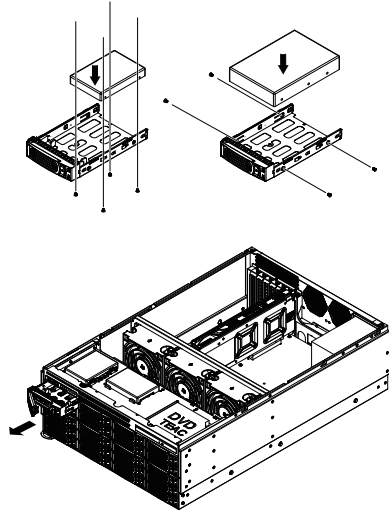

9. Secure top cover back onto chassis

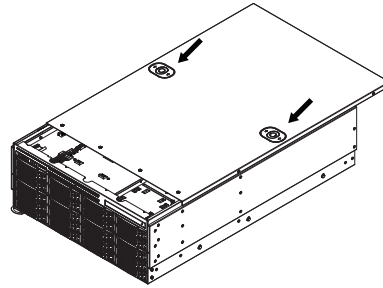

10. Install chassis' ear kit on to both sides of chassis

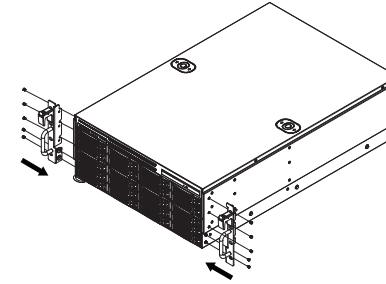

11. Pull out the inner rail of the sliding rail then secure it on both sides of the chassis

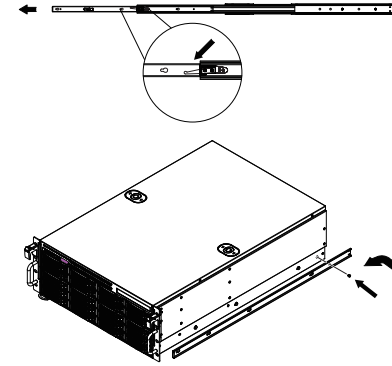

12. Install the sliding rails onto the server rack, then secure the front and rear with screws

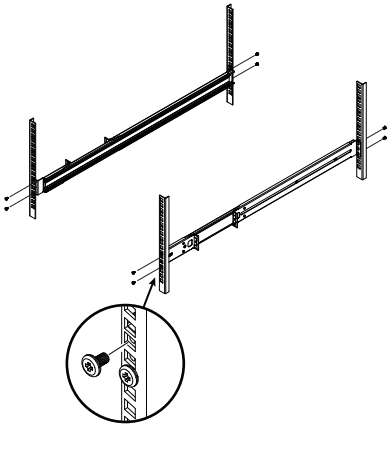

13. Pull out the middle part of the rails, align the inner rails onto the chassis, then slide the chassis into the server rack until the quick-release handle on the ear kit snaps into place with the server rack

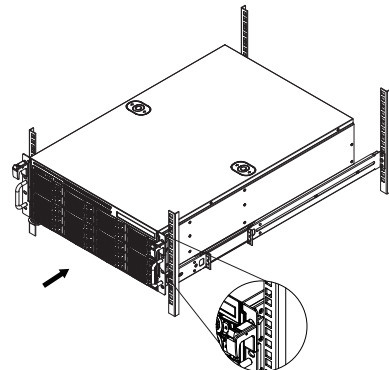

### Warranty Information

This product has a limited 1 year warranty in North America and Australia.  
For information on warranty periods in other regions, please contact your reseller or SilverStone authorized distributor.  
本产品自购买之日起, 于中国地区 (不包含澳门, 香港特别行政区) 享有一年有限质保 (部分产品为二年, 三年或五年)。详细保固年限请参考官方网站 <https://silverstonetek.com.cn/> 公布之产品型号为依据。

#### Warranty terms & conditions

- Product component defects or damages resulted from defective production is covered under warranty. Defects or damages with the following conditions will be fixed or replaced under SilverStone Technology's jurisdiction.
  - Usage in accordance with instructions provided in this manual, with no misuse, overuse, or other inappropriate actions.
  - Damage not caused by natural disaster (thunder, fire, earthquake, flood, salt, wind, insect, animals, etc...)
  - Product is not disassembled, modified, or fixed. Components not disassembled or replaced.
  - Warranty mark/stickers are not removed or broken.

Loss or damages resulted from conditions other than ones listed above are not covered under warranty.
- Under warranty, SilverStone Technology's maximum liability is limited to the current market value for the product (depreciated value, excluding shipping, handling, and other fees). SilverStone Technology is not responsible for other damages or loss associated with the use of product.
- Under warranty, SilverStone Technology is obligated to repair or replace its defective products. Under no circumstances will SilverStone Technology be liable for damages in connection with the sale, purchase, or use including but not limited to loss of data, loss of business, loss of profits, loss of use of the product or incidental or consequential damage whether or not foreseeable and whether or not based on breach of warranty, contract or negligence, even if SilverStone Technology has been advised of the possibility of such damages.
- Warranty covers only the original purchaser through authorized SilverStone distributors and resellers and is not transferable to a second hand purchaser.
- You must provide sales receipt or invoice with clear indication of purchase date to determine warranty eligibility.
- If a problem develops during the warranty period, please contact your retailer/reseller/SilverStone authorized distributors or SilverStone <http://www.silverstonetek.com>. Please note that: (i) You must provide proof of original purchase of the product by a dated itemized receipt; (ii) You shall bear the cost of shipping (or otherwise transporting) the product to SilverStone authorized distributors. SilverStone authorized distributors will bear the cost of shipping (or otherwise transporting) the product back to you after completing the warranty service; (iii) Before you send the product, you must be issued a Return Merchandise Authorization ("RMA") number from SilverStone. Updated warranty information will be posted on SilverStone's official website. Please visit <http://www.silverstonetek.com> for the latest updates.

### Additional info & contacts

**For North America** ([usasupport@silverstonetek.com](mailto:usasupport@silverstonetek.com))  
SilverStone Technology in North America may repair or replace defective product with refurbished product that is not new but has been functionally tested.  
Replacement product will be warranted for remainder of the warranty period or thirty days, whichever is longer. All products should be sent back to the place of purchase if it is within 30 days of purchase, after 30 days, customers need to initiate RMA procedure with SilverStone Technology in USA by first downloading the "USA RMA form for end-users" form from the below link and follow its instructions.  
<http://silverstonetek.com/contactus.php>  
**For Australia only** ([support@silverstonetek.com](mailto:support@silverstonetek.com))  
Our goods come with guarantees that cannot be excluded under the Australian Consumer Law.  
You are entitled to a replacement or refund for a major failure and for compensation for any other reasonably foreseeable loss or damage.  
You are also entitled to have the goods repaired or replaced if the goods fail to be of acceptable quality and the failure does not amount to a major failure.  
Please refer to above "Warranty terms & conditions" for further warranty details.  
SilverStone Technology Co., Ltd. 12F No. 168 Jiansong Rd., Zhonghe Dist., New Taipei City 235 Taiwan R.O.C. +886-2-8228-1238 (standard international call charges apply)  
**For Europe** ([support.eu@silverstonetek.de](mailto:support.eu@silverstonetek.de))  
**For China** ([support@silverstonetek.com.cn](mailto:support@silverstonetek.com.cn))  
**For all other regions** ([support@silverstonetek.com](mailto:support@silverstonetek.com))

零件名称 (Component Name)	有害物质/元素及其化学含量表 (Hazardous Substances and Chemical Content Table)					
	铅 (Pb)	汞 (Hg)	镉 (Cd)	六价铬 (Cr(VI))	多溴联苯 (PBB)	多溴二苯醚 (PBDE)
机壳 (Metal Case)	○	○	○	○	○	○
风扇 (Fans)	○	○	○	○	○	○
线材 (Cables)	○	○	○	○	○	○
螺丝 (Screws)	○	○	○	○	○	○
包材 (Packaging)	○	○	○	○	○	○

本表格依据 RoHS 11364 的规定编制。  
○ 表示该有害物质在该部件所有均质材料中的含量均在 GB/T 26572 规定的限量要求以下。  
— 表示该有害物质至少在该部件的某一均质材料中的含量超过 GB/T 26572 规定的限量要求。  
RoHS 11364 符合性声明

